

## Linear Actuators for Plant Valves

### PA-2000

#### Pneumatic Valve Actuators

The PA-2000 Pneumatic Valve Actuators Series is available for ON/OFF Control.

The actuator can be combined with VG8000 and VG8300 series in accordance with the maximum close-off pressure ratings specified.

The fail safe position of the PA-2000 can be changed in-situ with a conversion kit.

#### Features

- Manual override
- Reversible action in-situ
- Accessories available

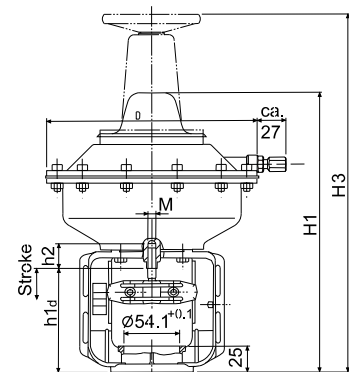

Dimensions in mm

Ordering Codes*	Handwheel	Spring Range	Diaphragm Area	Stroke
PA-20x0-32y2	---	20 - 50 kPa	150 cm <sup>2</sup>	13 mm
PA-21x0-32y7	•	70 - 100 kPa		
PA-20x0-33y2	---	20 - 50 kPa	300 cm <sup>2</sup>	25 mm
PA-21x0-33y7	•	70 - 100 kPa		
PA-20x0-36y2	---	20 - 50 kPa	600 cm <sup>2</sup>	42 mm
PA-21x0-36y7	•	70 - 100 kPa		25 mm
PA-20x0-37y2	---	20 - 50 kPa		
PA-21x0-37y7	•	70 - 100 kPa		

#### Notes

- \* = **x:** 0 = Without Positioner  
3 = With Positioner (PR10)
- y:** 1 = DA Actuator stem extends  
2 = RA Actuator stem retracts